

性能参数 Specifications

安装扭距: 10-15Nm
 工作温度: -30°C ~ +110°C
 工作压力: 最大1bar
 密封材料: 丁晴橡胶
 Installation torque: 10-15Nm
 Operation temperature: -30°C ~ +110°C
 Working pressure: 1bar
 Seal: NBR



订货代码 Ordering Code

液位计 Fluid level gauge

液位计长度 Length H

076,127,176,254,305

形式 Type

A型 Type A

液温形式 Temperature type

M - 温度计 Temperature meter

G - 温度表 Temperature gauge

T60,T70, T80 - 60°C, 70°C, 80°C 温度开关 Thermo switch

安装螺栓 Mounting bolt

M10, M12 (温度表型和温度开关型只有 M12, Temperature gauge and thermo switch M12 only)

FLG 127 A T70 M12

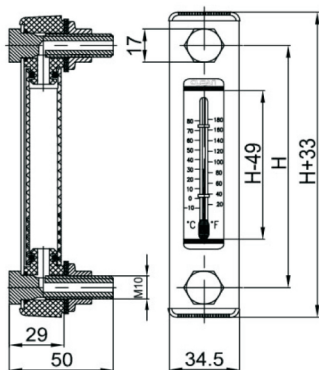

M 温度计型
Type M: Temperature meter

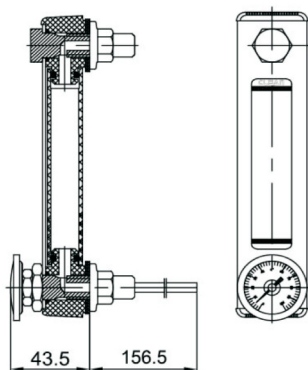

G 温度表型
Type G: Temperature gauge

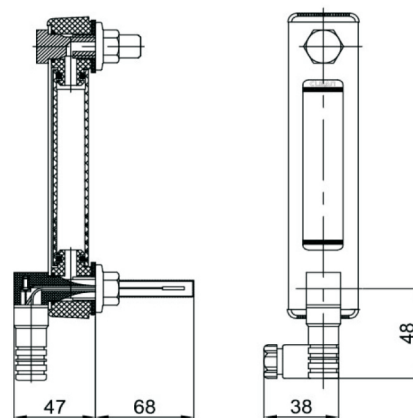

T 温度开关型
Type T: Thermo switch

	温度开关参数 Data:	
	电气插头 Plug:	DIN43650
	接线 Wiring:	1-2 (常闭 NC)
	最大电压 Voltage:	250VAC/50VDC
	最大电流 Current:	0.5A
	防护等级 Protection:	IP65

性能参数 Specifications

安装扭距: 10-15Nm

工作温度: -30°C ~ +110°C

工作压力: 最大 1bar

密封材料: 丁晴橡胶

Installation torque: 10-15Nm

Operation temperature: -30°C ~ +110°C

Working pressure: 1bar

Seal: NBR



订货代码 Ordering Code

液位计 Fluid level gauge _____

液位计长度 Length H _____

076,127,176,254,305

形式 Type _____

NO: 液位开关常开 Level switch N.O., NC: 液位开关常闭 Level switch N.C.

液温形式 Temperature type _____

M - 温度计 Temperature meter

G - 温度表 Temperature gauge

T60, T70, T80 - 60°C, 70°C, 80°C 温度开关 Thermo switch

安装螺栓 Mounting bolt _____

M10, M12 (温度表和温度开关只有M12, Temperature gauge and thermo switch M12 only)

FLG 127 NO T70 M12

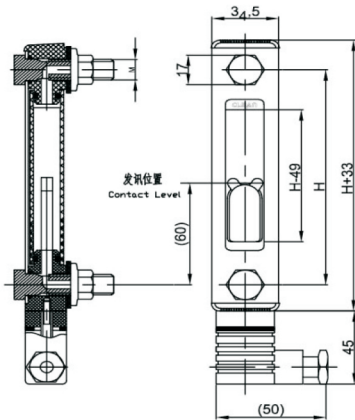

M 温度计型

Type M: Temperature meter

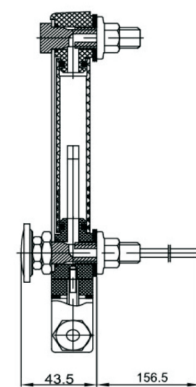

G 温度表型

Type G: Temperature gauge

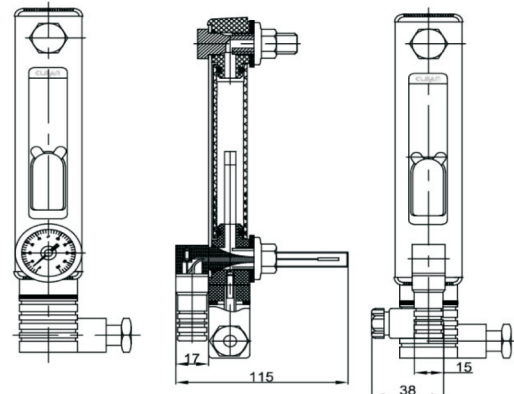

T 温度开关型

Type T: Thermo switch

	液位开关参数 Data:
	电气插头 Plug: DIN43650
	接线 Wiring: 1-2 (常开/常闭 NO/NC)
	最大电压 Voltage: 250VAC/50VDC
	最大电流 Current: 0.5A
防护等级 Protection: IP65	

	温度开关参数 Data:
	电气插头 Plug: DIN43650
	接线 Wiring: 1-2 (常闭 NC)
	最大电压 Voltage: 250VAC/50VDC
	最大电流 Current: 0.5A
防护等级 Protection: IP65	



性能参数 Specifications

安装扭距: 10-15Nm
 工作温度: -30°C ~ +110°C
 工作压力: 最大1bar
 密封材料: 丁晴橡胶
 Installation torque: 10-15Nm
 Operation temperature: -30°C ~ +110°C
 Working pressure: 1bar
 Seal: NBR



订货代码 Ordering Code

液位计 Fluid level gauge _____
 液位计长度 Length H _____
 076,127,176,254
 形式 Type _____
 B型: Type B, C型: Type C
 液温形式 Temperature type _____
 N - 无 Without, M* - 温度计 Temperature meter
 * C型无温度计, No temperature meter for type C
 安装螺栓 Mounting bolt M10 _____

FLG 127 B M M10

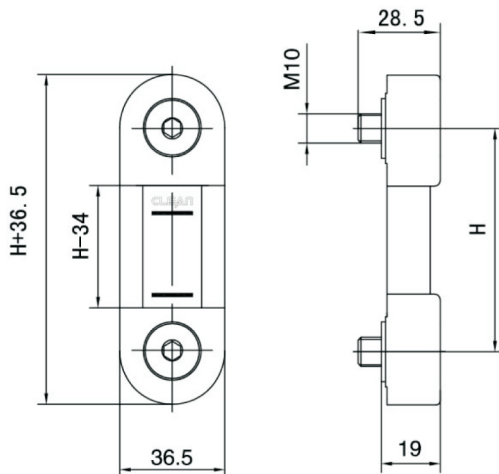

B型 Type B

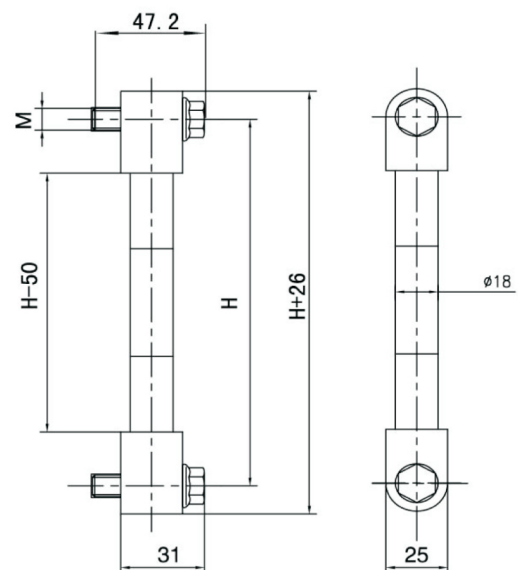

C型 Type C